

Zeus ZS-1 HF transceiver

A fully digitised SDR transceiver with general coverage reception

The new Zeus ZS-1 HF transceiver is a fully digitised design featuring continuous general coverage reception from 300kHz through to 30MHz plus up to 15 watts transmit on the classic bands plus WARC bands. Being a fully digitised SDR transceiver, the hardware is virtually a 'black box' (silver in this case!) that carries all the interconnections with the transceiver's controls created through the PC software. The original hardware design and software development was by PARS LLC in Saint-Petersburg, Russia with Alexandr Gromov (UB1AGD) responsible for the hardware and Yan Alekseenko the software. The model reviewed here was built under licence by SSB-Electronic in Lippstadt, Germany.

HOW IT WORKS. You can see a simplified block diagram of the Zeus ZS-1 in **Figure 1**. Following the surge protection, the antenna is fed to a software controlled 0 – 30dB attenuator (10dB steps) that is used to manage the input level to avoid overloading the Analogue to Digital Converter (ADC). The output of the attenuator passes via a 1.5MHz high pass filter for frequencies above 1.5MHz thus reducing the risk of overload from powerful medium wave broadcast stations. This is followed by a 30MHz low pass filter to eliminate signals outside the receiver's high frequency range. Before being applied to the main pre-selector filters, the ZS-1 has a switchable Low Noise Amplifier (LNA) that can be used to provide 14dB of additional gain. The main pre-selector filter bank comprises a set of 7 filters to cover the amateur bands. This same bank of filters is used for the transmit signal so large toroids were employed as you can see in **Photo 1**.

For use outside the amateur bands, the pre-selector can be bypassed in software by routing the signal via an attenuator that's set to match the loss of pre-selector filters. Following the pre-selector the signal is further amplified using a (LNA) and applied to the ADC via another 30MHz low pass filter. The ADC employed in this design is the Linear LTC2217, which provides 16-bit digitisation and is set to sample at a rate of 100 million samples per second (MSPS). The resulting output is a stream of 16-bit parallel words arriving at a rate of 100 million per second! That's a lot of data to process and way too much to try and send to a PC. This is where the Field Programmable Gate Array (FPGA) comes into its own. These devices contain a wide range of high speed

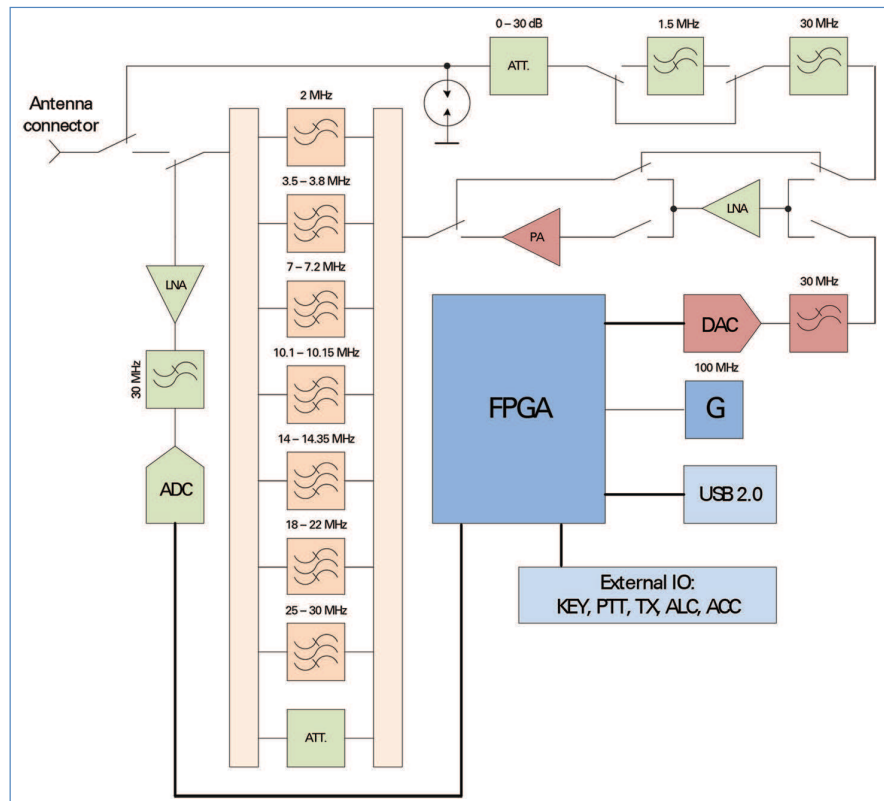

FIGURE 1: Simplified block schematic of the Zeus ZS-1 digital transceiver.

processing blocks that can be configured in software to create complex digital signal processing systems. The Zeus ZS-1 employs an Altera Cyclone III FPGA to do all the high power processing as well as providing the general control of the transceiver's functions. In the receive mode the main role of the FPGA is to provide a more manageable slice of digitised bandwidth that can be passed to the PC for processing and demodulation. This process is known as decimation and the output is a stream of IQ data that can be set to one of 9 pre-set bandwidths between 10kHz and 4MHz.

The transmit path is relatively simple as the modulated transmit signal is generated entirely in the digital domain by utilising a combination of the PC control software and the FPGA. The 14-bit output from the FPGA is applied to a Digital to Analogue Converter (DAC) running at 100MSPS where the output is a low-level, modulated, analogue signal at the chosen frequency. This signal passes via a 30MHz low-pass filter to the same LNA as used on receive. When the ZS-1 is used in its low power mode, this amplifier can provide up to 40mW of RF

output. In normal use, the output of the LNA feeds a Class AB power amplifier using a pair of RD16HHF power MOSFETs that delivers up to 15 watts RF output. The PA or LNA output is then applied to the main pre-selector bank for final filtering before passing to the antenna.

CONNECTING UP. The ZS-1 is supplied with a CD-ROM containing the operating software along with the operating manual in PDF format and a USB lead for connection to the PC. **Photo 2** shows the rear panel of the Zeus ZS-1 where all the connections are made. The power requirement is 12 – 15V DC at 4A using a standard coaxial power connector. The antenna connector is a SO-239 50Ω device and the USB link is via a mini-USB connector. A wing nut terminal was also provided for the station earth. For Press-To-Talk (PTT) control there was a 6.3mm stereo jack where grounding of the tip put the ZS-1 into transmit. This connection could also be used to transmit an unmodulated carrier by grounding the ring of the jack. The key connection also used a stereo jack and could handle straight or

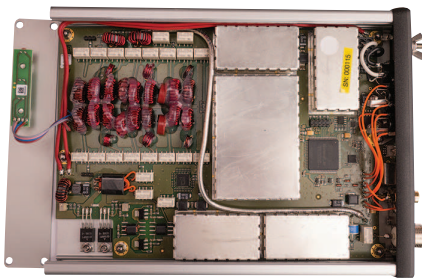

PHOTO 1: Internal view of the Zeus ZS-1 showing the Tx/Rx filter bank.

paddle keys with the precise keying function configured via the PC software.

The audio in for the microphone (or datamodes) and audio out to the speaker employed the PC's audio system. Selecting the appropriate soundcard was done using a separate audio panel accessed via the Settings menu. Here I was able to select from any of the soundcards connected to my PC. This selection could also be done on the fly without having to close and restart the software, which was helpful. If you've used SDRs previously you may have noticed that there's a processing delay that can be off-putting. The ZS-1 audio settings gave me the opportunity to choose an ASIO driver to minimise that delay. The ZS-1 also included an optional pseudo stereo effect that claimed to help improve readability. I'm not sure of the benefit but it sounded pleasant enough.

The ACC socket was provided for the control of miscellaneous external equipment such as linears, pre-selectors, antenna switches, etc. The ZS-1 provided 8 control channels each of which had an open collector output that could source up to 150mA at 24V. The action of each channel was programmable in the PC control software. The Tx jack provided another 150mA/24V open collector output that was activated on transmit. Finally, the ALC jack was for the power amplifier ALC connection and could accept a negative going voltage ranging from 0 to -10V DC. When choosing a shack location for the ZS-1 I had to bear in mind that the top panel is used as the heat sink so needs a free flow of air. During the review the case ran gently warm to the touch during receive but became quite hot during prolonged data modes usage. However, there was a temperature monitor visible at the top of the display that provided software protection against overheating.

RIG CONTROL. Whilst the ZS-1 doesn't have a conventional CAT connector on the rear panel, it can still be controlled by third party software using what are known as virtual COM ports. To support computer control, the ZS-1 emulates the Kenwood TS-590 command set and the COM port and baud rate can be set up using the Server tab in the Settings menu. Because

the control program and the transceiver are all created in software, there is no need to use real hardware COM ports. The solution is to use a software utility to create a pair of connected virtual COM ports. The ZS-1 manual suggests using *com0com* (<http://sourceforge.net/projects/com0com/>) so that's what I used for the review. In order to be able to use a variety of datamodes as well as other CAT software, 2 pairs of virtual COM ports are required, one for the main CAT control data and the other for simple control of the PTT and KEY lines. To make sure everything was working, I used the free *ComTestSerial* software (www.microridge.com/comtestserial.htm) to check the ZS-1 was responding to commands correctly.

When using data modes software with the ZS-1 or any other SDR receiver, you need a way to get the audio from the receiver into the decoder. Whilst this can be done by patching inputs to outputs on sound cards there is a much better way. When you patch inputs to outputs you introduce two analogue to digital conversions that will degrade the signal. The best way to patch without cables is to use a Virtual Audio Cable (VAC) utility. By far the best and most popular is VAC by Eugene Muzychenko. You can get the software here: <http://software.muzychenko.net/eng/vac.htm>.

By using the VAC, the audio remains in the digital domain as it moves between the receiver and decoder and vice-versa.

BASIC OPERATION. With all the necessary connections complete, it was time to start tuning around. As you can see from the screen shots, the ZS-1 uses a conventional SDR layout with spectrum and waterfall displays dominating the main display. With this type of display the primary tuning method is point and click and this was very well implemented in the ZS-1 software. A single left-click anywhere on the display and the receiver immediately re-tuned to that frequency. I could also tune around by dragging the frequency ribbon in the centre of the display. For more precise tuning with the ZS-1, I could place the cursor over any digit on the main frequency display and left-click at the top of the number to increase or the bottom to decrease the frequency. Fine tuning could also be carried-out by rotating the mouse wheel and I found this excellent for fine tuning SSB signals. The frequency step for each rotational click of the mouse wheel could be set to one of eight settings between 10Hz and 10000Hz. Getting around the amateur bands and mode selection was particularly easy thanks to the pre-set buttons at the top of the display. The Zeus ZS-1 also features two VFOs and I was able to quickly move between

the two VFOs and swap values.

As mentioned earlier, the frequency span of the display could be altered and this was done by right-clicking anywhere on the display area. The nine options provided ranging from 10kHz to 4MHz wide, which should easily cover most requirements.

The ZS-1 includes multiple controls for managing the Automatic Gain Control (AGC). First up is the HF-AGC that controls the 0 – 30dB attenuator and the 14dB gain LNA ahead of the main ADC. This could be manually controlled or set to HF AGC Min to provide the best signal to noise ratio or HF AGC Max to simply avoid ADC overload. The second AGC controls dealt with the audio AGC and here you could adjust the speed and threshold values.

One of the strengths of most SDR systems is the excellent software filters and the ZS-1 does well in this area. By using a couple of sliders, the LF and HF cut-off points could be adjusted between 0Hz and 20kHz. I could also drag the bandwidth using the mouse pointer on the main display. Noise reduction filters were also provided with simple but adjustable broadband noise and automatic notch filters.

TIME MACHINE. One feature I particularly liked was the time slip control on the waterfall display. This appeared as a red arrow on the right hand side of the display that was normally aligned with the top of the waterfall. However, you could drag this down the display and it would play back a signal that had already passed down the waterfall. The maximum slip available was 2.5 minutes. But, in most cases, just being able to step back a few seconds was enough to recover a missed name or callsign.

TRANSMIT AUDIO. The ZS-1 included an excellent system for adjusting the transmit audio quality. With many rigs we have to rely on others comments to fine tune speech processors for the best communications audio but the ZS-1 has a better way. Using the TX Signal Settings panel, you first make a recording of your voice with your chosen microphone. Next you play back the recording and adjust the speech processor settings until you have your ideal audio. The voice recording plays back in a continuous loop so you can take as long as you like to get the sound just the way you want. To help get this right, the panel includes a spectrum display so you can see the spectral shape of your audio plus there is a 13-band



PHOTO 2: Zeus ZS-1 interconnections on the rear panel.



FIGURE 2: Zeus ZS-1 main screen.

graphic equaliser as well as adjustable dynamic and μ -Law compressors and an AGC system. I tried this system with lots of different microphones and managed to get a decent sound out of all of them. The panel includes the facility to save two pre-set processor settings though I would have liked to be able to save more than that.

Completing the transmit audio, the ZS-1 included the facility to transmit a pre-recorded audio file. This could be useful for CQ calls amongst other things. The file just needed to be in 16-bit wav format with a maximum length of 5 minutes. The only feature missing was VOX facilities.

CW PANEL. For the CW operator, the ZS-1 is very well equipped with plenty of configuration options. The key is connected via the stereo jack on the rear panel and the ZS-1 can be configured to handle straight, single lever paddles and iambic keys. The CW tone could also be adjusted in 100Hz steps from 300Hz to 1kHz. Speed adjustment was also provided in characters per minute along with a spacing adjustment. The ZS-1 supports semi break-in with adjustable fall-back time and the ability to extend the first character to account for TX switching delays. The CW Panel was supplemented with a text entry box for typed QSOs along with a capacity for 12 pre-recorded macros that could be used for common exchanges.

IQ VERSATILITY. The In-phase and Quadrature IQ signals are the life blood of all SDR systems and it is these signals that are streamed to the PC for filtering and demodulation. However, with disk space being so cheap these days, it is perfectly feasible to

record the IQ stream to disk for playback at a later time. The amount of disk space used by the ZS-1 depended on the bandwidth setting with a 10kHz bandwidth using 6MB per minute and the maximum recordable spectrum of 100kHz using about 44MB per minute. In addition to being able to make recordings, the ZS-1 software package includes a stand-alone IQ player that can be used to playback Zeus IQ files. The IQ player appeared to be a stand-alone version of the main software that was modified to handle recorded files. This included all the processing controls of the main software so it was like receiving the files all over again! When playing a recording, there is a handy progress bar at the bottom of the screen that could be used to fast-forward or re-wind to a section of interest. There are lots of uses for IQ recording, eg recording activity during a contest, recording activity during a band opening, etc.

EXTERNAL CONTROL. The external control facilities of the ZS-1 were very well implemented with eight separate open collector outputs available. The action of each line could be programmed using the External Control Panel. Activation points were available for each of the 9 amateur bands and triggered by Tx, Rx or both conditions. There were also settings for Tx on/off delays as well as ALC start and end voltage settings. If you need to control external fans or similar devices, there is also a configurable PWM (Pulse Width Modulation) output.

SERVER MODE. To support remote operation of the receiver, the ZS-1 software includes a server where its web address and communication port could be defined and the server activated. The server provides remote operation using *SDR-Console V1.5* or *SDRMAXIII* software. It should also be possible to provide fully remote LAN operation using one of the Silex USB-LAN servers but I didn't have the opportunity to try this.

ON THE AIR. I had the ZS-1 on review for several weeks so had the opportunity try it on lots of different bands and operating modes. The low power was no problem for me as I prefer to operate QRP and in most cases I used the ZS-1 running about 10 watts or less directly into my Butternut HF9V vertical antenna.

I found the tuning system of the ZS-1 to be particularly good and seemed to combine the best features of the SDR designs that are around at the moment. I found the time machine option particularly helpful for recovering a missed name or QTH. As I mentioned earlier, adjusting the speech processing using a voice recording worked extremely well as I was able spend time getting

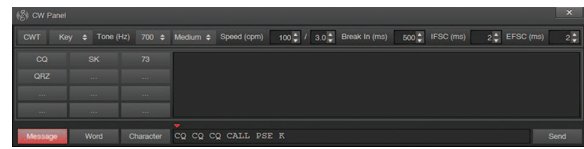

FIGURE 3: The ZS-1 CW settings panel.

the sound just how I like it. Even a webcam mic ended-up sounding pretty good! This was backed up by good on-air audio reports from other amateurs. The variable filtering worked extremely well as you would expect from an SDR design and it was very useful to be able to tighten up the selectivity when the bands got busy. Once I'd set-up the virtual COM ports I tried controlling the ZS-1 with *Ham Radio Deluxe v5 (HRD)* and this worked fine, provided you un-tick the RTS and DTR boxes on the *HRD* connection panel. Next up was some data modes operation using FLDIGI. For this operation I set FLDIGI to manage the Tx/Rx switching using the PTT line via the second virtual COM port. This also worked extremely well and I was soon making contacts into the Caribbean and South America on 21MHz using PSK-31 with just 10 watts. I found the variable filters particularly helpful on PSK as I normally operate PSK with the filter set at around 2.8kHz so I can see the whole PSK segment. However, if a strong signal appears on the band whilst you're working a weak signal the AGC usually kicks in and wipes out your weak signal! With the ZS-1 I could quickly narrow the receive bandwidth to exclude the strong signal and carry on working my DX. In fact, a better way of working DX is to narrow the bandwidth once you've established contact. Having spent some time with the transceiver I think the interface could be improved with the addition of tooltips. These are the small text boxes that appear when you hover over a button. Without tooltips to remind me, I found myself having to refer back to the manual to check the function of infrequently used controls.

SUMMARY. The Zeus ZS-1 is an excellent digital transceiver with a particularly good user interface that made it a pleasure to use. The range of control provided was excellent and I was particularly impressed with the clever speech processing adjustment system. On air, the transceiver had many good reports and worked effortlessly across a wide range of operating modes. Full details and the specification can be found at the SSB Electronic website at: www.ssb.de/product_info.php?language=en&info=p3407_Zeus-ZS-1-Transceiver.html

The Zeus ZS-1 is available from SSB-Electronic GmbH and costs €1,499. My thanks to SSB-Electronic for the loan of the review model and to Willi Passmann, DJ6JZ and Alexandr Gromov, UB1AGD for their generous technical support in writing this review.



FIGURE 4: The ZS-1 transmit audio processing panel.